

Photovoltaic Energy: Research, Training and Development of Rural Areas in Eastern of Morocco

K. Hirech⁽¹⁾, M. Melhaoui⁽¹⁾, I. Atmane⁽¹⁾, K. Kassmi^(1,2), N. Bachiri⁽²⁾

¹⁾ Physics Department, Faculty of Science, Mohamed the First University, *LETSER, Team of Electronic Materials & Renewable Energy (EMRE)*, Oujda 60000, Morocco

²⁾ Association Homme and Environnement of Berkane AHEB
hirech@gmail.com, khkassmi@yahoo.fr

Abstract—The work presented in this paper comes within the framework of a university partnership and socioeconomic sectors HAE Association and National Initiative for Human Development (NIHD) established by the Moroccan government for the development of rural communities whose their resources are limited. The main objective is on the one hand, the promotion of renewable energy, photovoltaic, and on the other hand, the opening of the university on the socioeconomic environment, which aims to improve the population life conditions of isolated zones through the installation of photovoltaic plants (PV). In fact, in this article we contribute in improving the functioning of PV installations. This is by the insurance of better adaptation of the PV generator to the load regardless sudden changes of weather conditions and with a proposed MPPT control, in order to decrease losses and reduce operating costs

Keywords—Photovoltaic energy; lighting homes; water pumping; Boost converter; MPPT controller; Batteries;

I. INTRODUCTION

Currently, the use of conventional solar kits does not cover the needs and requirements of the inhabitants. The cost of the PV installation is relatively large compared to electrical power provided [1-2]. Therefore, the improving of the PV installations conception is needed in order to reduce the cost and improve their energy performances [3]. Moreover, nationally, the Moroccan government encourages the use of photovoltaics energy particularly in rural areas. In the agricultural field, subsidies of up to 70% of the photovoltaic system cost are granted for irrigation. This reduced considerably the cost of electrical energy supplied [4].

In addition to environmental issues, the sector is very promising for the development of employment, particularly in the eastern region of Morocco (Oujda) impacted directly by the studies that are conducted as a part of this project. Nationally, the National Office of Electricity and drinking water adopted since 1996 a strategy for electrification of isolated sites where the connection cost is very expensive by photovoltaic kits (systems) [5-6]. Furthermore, in the provinces of the Oriental Region and in the domain of agriculture, the irrigation of fields by using diesel returns

expensive for farmers. The use of photovoltaic renewable energy reduces energy costs and minimizes excluding of isolated and deprived areas [7-8-9].

The reflection on the elimination of these difficulties and the provision of adequate solutions will form a scientific interest and economic development of the region with a great importance. The shutters provided in these works are:

- ▶ Awareness of rural communes on the PV stations benefits.
- ▶ Show that renewable energy is a sustainable solution for lighting homes and water pumping...
- ▶ Research and training on the concerned theme: The realized PV installations represent a platform for research, training for students and trainees Moroccans and foreigners (Tunisia, France, Belgium).

Also, as part of research provided by the EMRE team because of the difficulties observed during the PV systems operation and especially in the absence of adaptation [10] and the limitation of the MPPT control of the literature [11]. The EMRE team has proposed and presented techniques, simulation and experimental results of a digital MPPT controller designed for stand-alone installations. The MPPT controller was tested on a prototype of a PV system realized in the laboratory. This will be followed by studies to integrate this control in medium and high power installations developed.

In this paper, we present the projects that our team has achieved in the rural world (lighting, water pumping...), then the first results of studies done in the laboratory, design, implementation and operation of control blocks of PV systems.

II. PV INSTALLATIONS IN RURAL WORLD

Since the implementation of the PV installations (lighting and pumping) the research works shows that, the PV installations (Photos 1-3) cover the needs of inhabitants into electrical energy and pumped water. The detailed analysis of the optimal functioning of PV installations shows that the electrical power losses can reach 30% (Fig. 1). However, to

reduce these losses and reduce the overall cost of the PV installations, our team develops and proposes, on the market, equipment of power, of control, of regulation, of a management (Fig. 2) and of discretized architectures (Fig. 3).

In the following of this work, we present the study and the results that show the utility of the optimization of PV installations operation by improving the MPPT control performances developed into the laboratory. This is in order to reduce the power losses concluded in conventional PV installations and to reduce the operating cost (Fig. 1).



Photo 1: lighting PV Installation (2 kW), in the framework of PNUD and BTC projects in Douar Zragta of the Issly rural commune of Oujda Morocco



Photo 2: Pumping PV installation (2 kW), in the framework of UNDP and BTC projects in Douar Zragta of the Issly rural commune of Oujda Morocco



Photo 3: Water pumping plant (15 kW) in the framework of the NIHD, for domestic use (20 homes) and irrigation of 100 hectares in the rural commune of Tafoghalt. (Berkane).

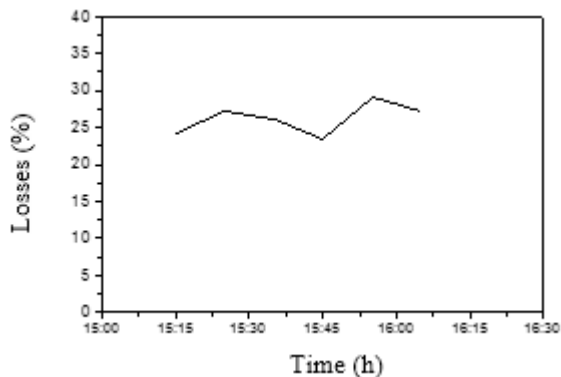

Fig.1: Losses of electrical energy generated by photovoltaic installations.

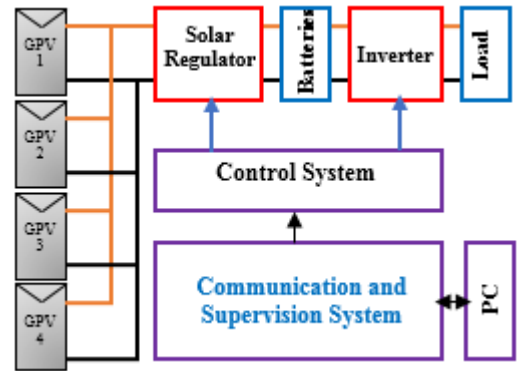

Fig. 2: lighting installation architecture equipped with the supervision and communication system.

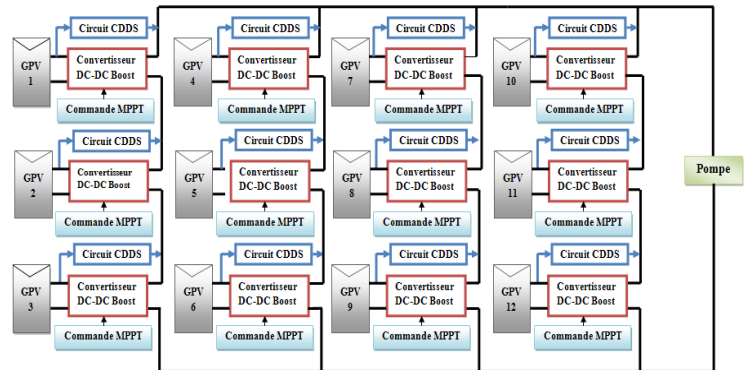

Fig. 3: New architecture of the PV pumping station.

III. OPTIMISATION TECHNIQUE OF THE PV INSTALLATIONS OPERATION

To facilitate the task of study the PV installations presented in Fig. 2 and Fig.3, we have realized, at first, a stand-alone PV system, which the block diagram is shown in Fig. 4, this installation, consists essentially of:

- ▶ A photovoltaic panel type SP75 [12].
- ▶ Two solar batteries in series. [12]
- ▶ A power converter DC-DC Boost type [12]
- ▶ An interface for communication and management of electrical quantities acquired from the PV system. [13]
- ▶ A digital MPPT control developed in the laboratory. This controller tracks the PPM of the PV panel whatever the weather conditions by maximizing the power of the batteries following Equation:

$$\frac{dP_{BAT}}{dt} \Big|_{P_{MAX}} = 0 \quad (1)$$

The optimization of the PV system operation is performed by the algorithm of Fig. 5, which allows the search of the PPM from the regulation of the power to the output of the converter (equation 1). This by the Boost switch control using a PWM signal of a frequency of 10kHz and a variable duty cycle that depend on the results of the following tests:

- If $\frac{dP_{BAT}}{dt} > 0$, the system evolves to the PPM. It keeps the same direction of development either by incrementing the duty cycle in the case of $(d\alpha) / dt > 0$ or decrement it when $(d\alpha) / dt < 0$.
- If $\frac{dP_{BAT}}{dt} < 0$, the power decreases at the output and therefore the system away from the PPM. This reaction of the system is caused by changes in weather or the oscillation of the system around the PPM point. In this case, an additional test is performed at each change of the evolution of the PV system. The results of this test determine the guidelines to be followed; If $T_m \geq \text{Delay}$: the algorithm tests the derivative of the duty cycle in order to reverse the direction of change of the system by incrementing the duty cycle if $(d\alpha) / dt < 0$ or decrement it when $(d\alpha) / dt > 0$. Otherwise, no operation is performed.

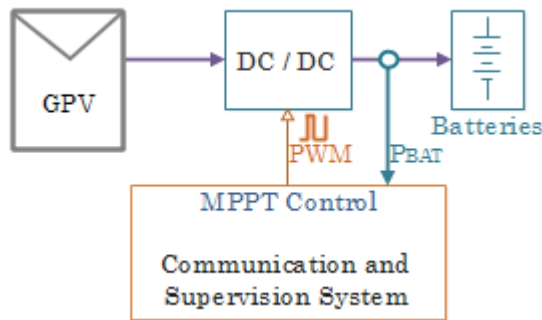

Fig.4: block diagram of the designed photovoltaic installation

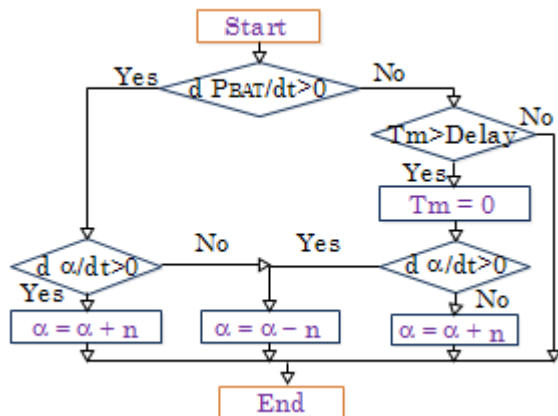

Fig.5: the proposed MPPT algorithm

IV. ACHIEVEMENT AND OPERATION OF THE BLOCK CONTROL IN LABORATORY

A. Experimental Procedure

The measure bench established to test the PV system realized and control systems are shown in Fig. 6c This bench

that is fully automated, is driven by the communication and supervision system (CSS) which is constituted by:

- ▶ A photovoltaic panel SP75, that can deliver a power of 55 W (Fig. 6 a) [12-13]
- ▶ Two solar batteries in series each one has a capacity of 110AH and a voltage of 12V [12-13]
- ▶ A Boost converter dimensioned for supporting a maximum current of 10A and a power of 200W [12]
- ▶ A weather station (pyranometer and a temperature sensor) whose role is to measure the intensity of irradiance and temperature (fig. 6 b).
- ▶ The digital MPPT control developed for the optimization of the stand-alone PV installation.
- ▶ A communication and supervision system (CSS) that manage the installation operation. It allows the acquisition, processing and storage of data (Fig. 7,A) and visualization of different electrical parameters in real time on a computer (Fig. 7,B).
- ▶ Measuring devices: Keithley multimeter, digital oscilloscope.

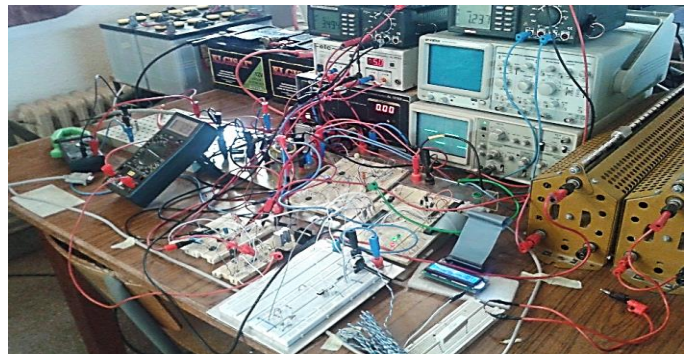

Fig. 6. Measure bench realized in the laboratory.

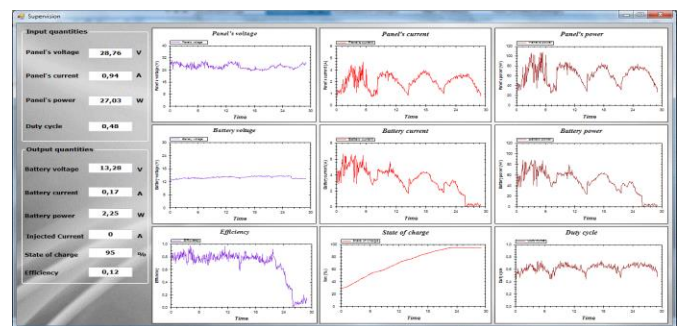

Fig. 7. The interface of communication and supervision system.

B. Optimal operation of the installation

During operation of the stand-alone photovoltaic installation realized, we have, at first, identified the different parameters (irradiance, temperature, duty cycle ...) and electrical quantities of the PV panel and batteries (voltage, current, power) automatically through the interface of

communication and supervision (CSS). In addition, and from these results, the interface allows concluding the efficiencies, especially, that of the Boost converter (η_{Con}) and the overall installation efficiency (η_{Sys}). These results are presented in Fig. 8. They illustrate the operation of the installation for 4 hours (10:00 to 14:00). In the same figure, we have presented the results of optimal simulation of all of these simulated quantities under the same conditions (irradiance, temperature) obtained from the Pspice simulator. These results show that:

- ▶ The experiment was carried out during a period from a day when the irradiance has fluctuated from 650 W / m^2 to 850 W / m^2 (Fig. 8 a)
- ▶ The V_{PV} voltage (Fig. 8 c), the current I_{PV} (Fig. 8, d) and power P_{PV} (Fig. 8 e) provided by the photovoltaic panel are in very good agreement with the optimal ones under the same conditions. Similarly, the V_{BAT} voltage (Fig. 8 f), current I_{BAT} (Fig. 8 g) and power P_{BAT} (Fig. 8, h) of the batteries charging are in agreement with those of the simulation.
- ▶ The proposed MPPT control allowed operating the installation in optimal conditions; especially it allows obtaining satisfactory efficiencies. In fact, it provides an overall average efficiency of around 9% (Fig. 8 j) and a conversion efficiency of the boost converter in the order of 88% (Fig. 8 i).
- ▶ The energy generated during the experimentation of the installation is in the order of 700 Wh by using MPPT control, and that produced optimally is in the order of 750 Wh and consequently the energy produced during the operation is very close to optimal one.

In conclusion, the experimental results validate those obtained by Pspice. This shows the utility and feasibility of the proposed MPPT control, in particular to optimize the operation of stand-alone PV installations, where the possibility of exploiting these performances to resolve operating problems of the PV installations optimization

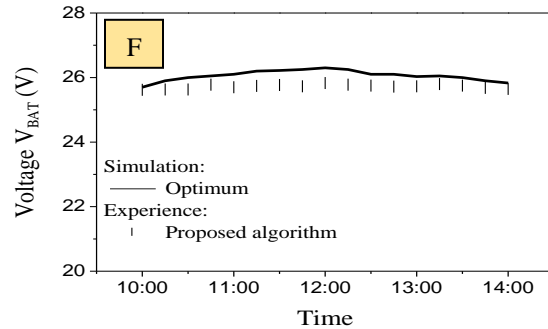
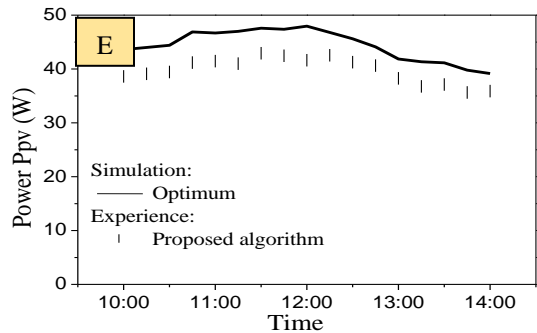
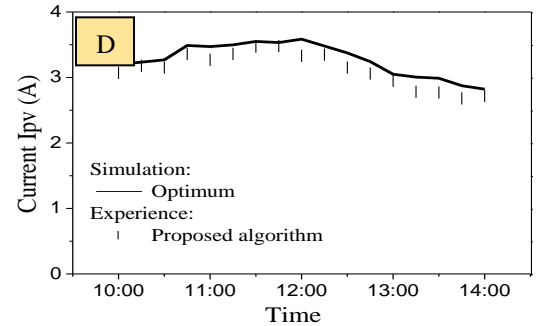
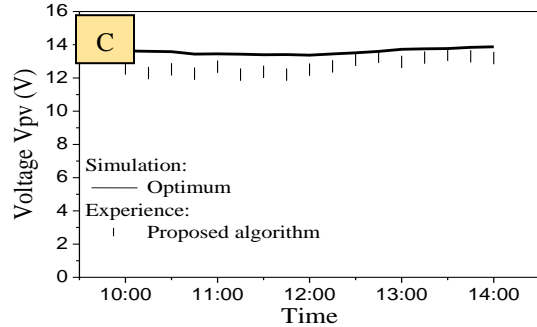
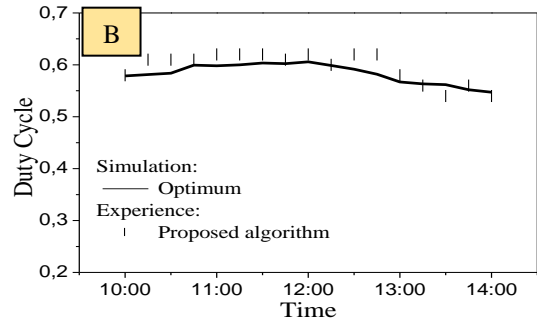
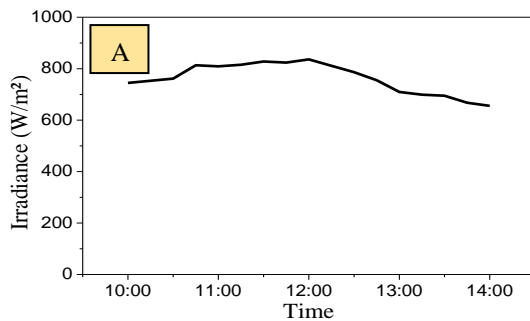

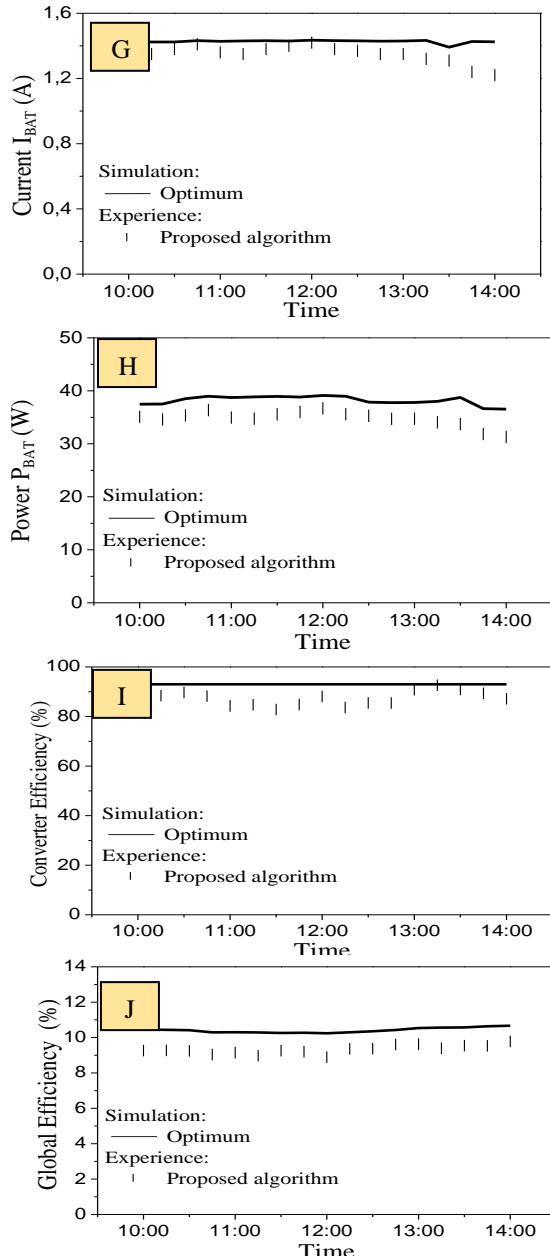

Fig. 8: Signals simulated and experimental electrical quantities of the MPPT Command studied during the experimental day. A: The irradiance in W / m^2 , B: the duty cycles. C: current I_{PV} , D: V_{PV} voltage, E: power P_{PV} , F: the current I_{BAT} , G: the V_{BAT} voltage, H: the power P_{BAT} , I: Performances of converter, J: total efficiency.

V. CONCLUSION

As a conclusion, all results achieved by the research team in the rural world in the development of rural areas show improvement in the life conditions of the inhabitants: lighting, refrigeration, irrigation fields... PNUD, BTC and NIHD projects allowed the inhabitants to be equipped with photovoltaic systems and to benefit from electrical energy in order to cover their daily needs (lighting, water pumping...).

In addition to that, all the experimental and simulation results obtained and presented in this work show that the prototype of the PV installation performed in the laboratory, works in optimal conditions under the control of the proposed MPPT command. This is independently of changes in weather conditions. The efficiencies concluded from the results presented, especially the average conversion efficiency (88%) and the average overall system efficiency (9%), witness the good operation of electrical / electronic circuits developed.

In perspective, the control and the optimization equipment and strategies developed by the EMRE team can be used in installations established in order to reduce the cost and to provide important energy production.

ACKNOWLEDGMENTS

This work is supported by: National Initiative for Human Development (NIHD), Belgian Development Agency CTB (Project MIP/012/010), Morocco, United Nations Development Programme UNDP Art Gold Morocco, ENV 2008 2 OO, Cooperation Moroccan-Belgian "Institutional University Commission", IUC, Oujda, 2008-2012 (Water and Environment Activity/Sub-Activity Renewable Energy).

REFERENCES

- [1] <http://www.photovoltaique.info/Couts-d-investissement.html>
- [2] <http://www.les-energies-renouvelables.eu/conseils/photovoltaique/cout-et-rentabilite-dune-installation-de-panneaux-solaires-photovoltaique/>
- [3] BAGHAZ Elhadi, Thèse de Doctorat en Sciences (Electronique, Energies Renouvelables (photovoltaïques)) : Architecture discrétisées de gestion de l'énergie fournie par les systèmes photovoltaïques. Université Mohamed Premier, N° 331/15, 2015, Oujda (Morocco),
- [4] Juang, P., & Kacira, M. (2013, October). System dynamics of a photovoltaic integrated greenhouse. In International Symposium on New Technologies for Environment Control, Energy-Saving and Crop Production in Greenhouse and Plant 1037 (pp. 107-112).
- [5] Atouk, S. (2013). Les énergies renouvelables et les populations rurales pauvres: le cas du Maroc.
- [6] http://ecolo.org/documents/documents_in_french/Solar-Temasol-Maroc-03-05.pdf
- [7] Schaber, K., Steinke, F., Mühlich, P., & Hamacher, T. (2012). Parametric study of variable renewable energy integration in Europe: Advantages and costs of transmission grid extensions. Energy Policy, 42, 498-508.
- [8] Scheer, H. (2013). The solar economy: Renewable energy for a sustainable global future. Routledge.
- [9] <http://www.indh.gov.ma/index.php/fr/presentation>
- [10] Khanna, R., Zhang, Q., Stanchina, W. E., Reed, G. F., & Mao, Z. H. (2014). Maximum power point tracking using model reference adaptive control. Power Electronics, IEEE Transactions on, 29(3), 1490-1499.
- [11] Abbes, H., Abid, H., Loukil, K., Toumi, A., & Abid, M. (2014). Etude comparative de cinq algorithmes de commande MPPT pour un système photovoltaïque. Revue des Energies Renouvelables, 17(3), 435-445.
- [12] K. Hirech, M. Melhaoui, F. Yaden, E. Baghaz, K. Kassmi, 'Design and realization of an autonomous system equipped with a regulator of charge/discharge and digital MPPT command', Energy Procedia. 42 (2013) 503-512
- [13] Hirech, K., Melhaoui, M., Malek, R., & Kassmi, K. (2016). A PV System Equipped with a Commercial and Designed MPPT Regulators. In Proceedings of the Mediterranean Conference on Information & Communication Technologies 2015 (pp. 493-503). Springer International Publishing.